

CONTROL ELECTRONIC CIRCUITS WITH THE OUTPUT OF THIS

LIGHT ACTIVATED SWITCH

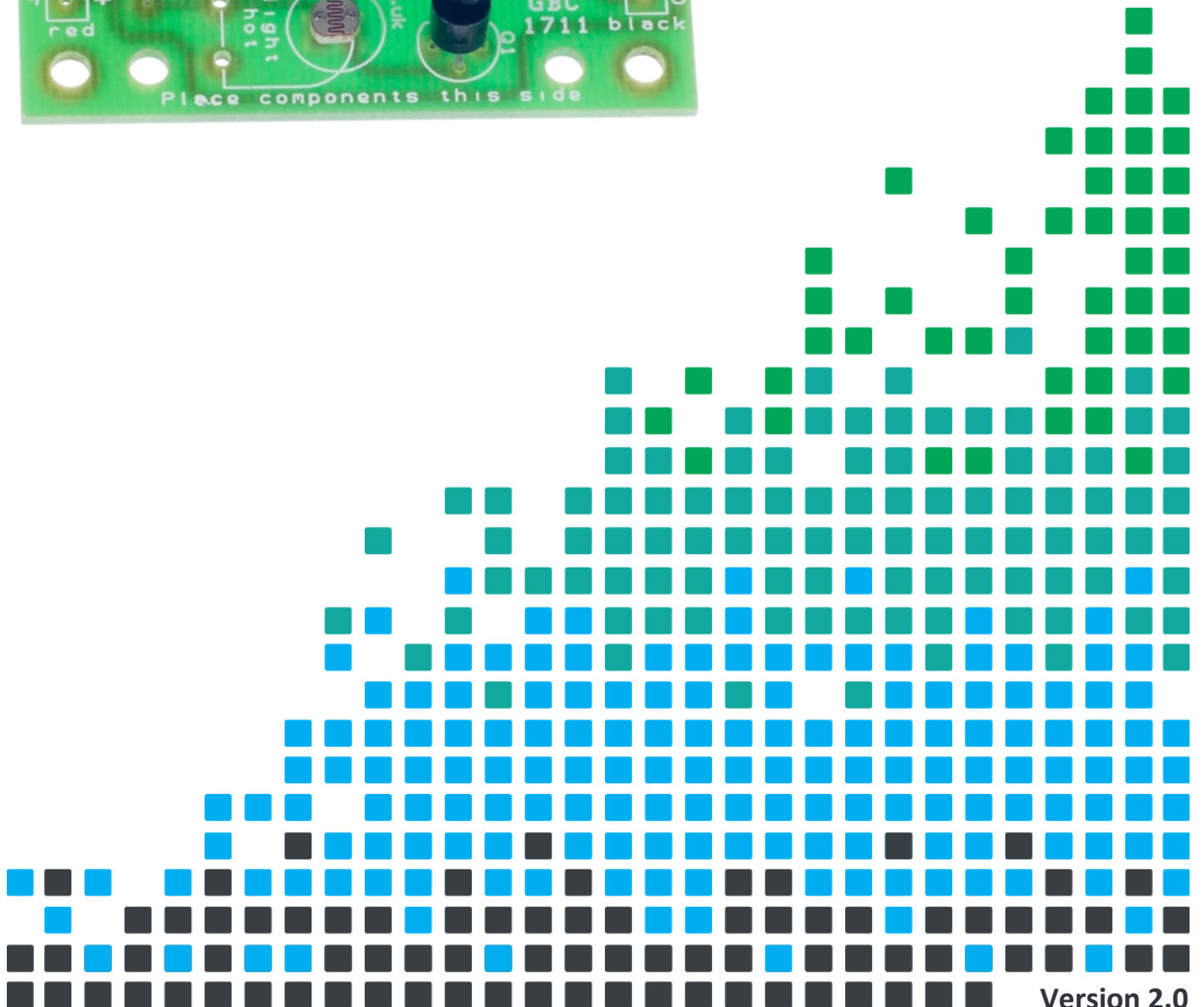
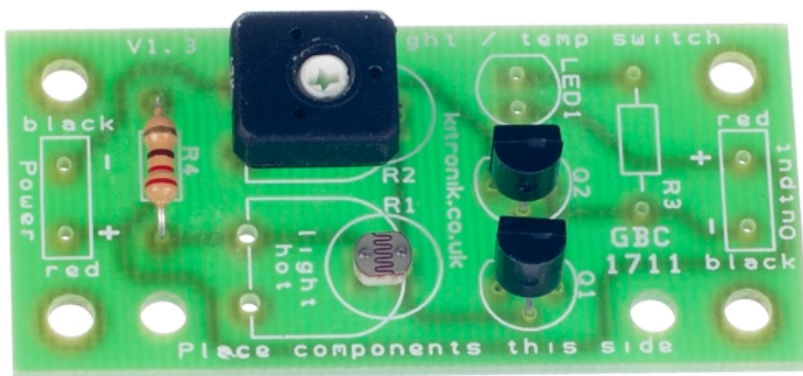

Build Instructions – Light Activated

Before you start, take a look at the Printed Circuit Board (PCB). The components go in the side with the writing on and the solder goes on the side with the tracks and silver pads.

1 PLACE RESISTOR

Start with the 220Ω resistor that is marked with red, red, brown coloured bands. Solder the resistor into the PCB where it is labelled R4. It doesn't matter which way around the resistor goes into the board.



2 PLACE THE TRANSISTORS

The two transistors should be placed into Q1 and Q2. It is important that they are inserted in the correct orientation. Ensure that the shape of the device matches the outline printed on the PCB. Once you are happy, solder the devices into place.



3 SOLDER THE LDR

Solder the LDR into the circle indicated by the text R1. This is next to the 'light' text. It does not matter which way around it is inserted.



4 SOLDER THE VARIABLE RESISTOR

Place the variable resistor into R2. It will only fit in the holes in the board when it is the correct way around.



Connecting power

There are two power terminals on the PCB to allow power to be connected. These are identified by the text 'power' on the PCB.

- The positive power connection should be connected to the terminal indicated by the text '+' and 'red'.
- The negative power connection should be connected to the terminal indicated by the text '-' and 'black'.

Connecting an LED

The circuit can be used to turn on an LED. The LED should be soldered into the LED1 on the PCB. A current limit resistor must also be placed in the R3 on the PCB. The value of R3 will depend on the LED used and the supply voltage. For a standard LED and a 5V supply voltage a 220Ω would be suitable.

Connecting an external circuit to the boards output

The circuit can be used to control another device. To do this the device that is to be controlled should be connected to the terminals labelled 'output'. When the circuit is activated the output turns on and can be used to turn on the device to which it is connected.

Note: This output will be around 0.9V lower than that connected to the PCB.

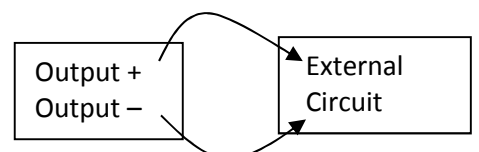

Build Instructions – Dark Activated

Before you start, take a look at the Printed Circuit Board (PCB). The components go in the side with the writing on and the solder goes on the side with the tracks and silver pads.

1 PLACE RESISTOR

Start with the 220Ω resistor that is marked with red, red, brown coloured bands. Solder the resistor into the PCB where it is labelled R4. It doesn't matter which way around the resistor goes into the board.



2 PLACE THE TRANSISTORS

The two transistors should be placed into Q1 and Q2. It is important that they are inserted in the correct orientation. Ensure that the shape of the device matches the outline printed on the PCB. Once you are happy, solder the devices into place.



3 SOLDER THE VARIABLE RESISTOR

Place the variable resistor into R1. It will only fit in the holes in the board when it is the correct way around.



4 SOLDER THE LDR

Solder the LDR into the circle indicated by the text R2. This is next to the 'dark' text. It does not matter which way around it is inserted.



Connecting power

There are two power terminals on the PCB to allow power to be connected. These are identified by the text 'power' on the PCB.

- The positive power connection should be connected to the terminal indicated by the text '+' and 'red'.
- The negative power connection should be connected to the terminal indicated by the text '-' and 'black'.

Connecting an LED

The circuit can be used to turn on an LED. The LED should be soldered into the LED1 on the PCB. A current limit resistor must also be placed in the R3 on the PCB. The value of R3 will depend on the LED used and the supply voltage. For a standard LED and a 5V supply voltage a 220Ω would be suitable.

Connecting an external circuit to the boards output

The circuit can be used to control another device. To do this the device that is to be controlled should be connected to the terminals labelled 'output'. When the circuit is activated the output turns on and can be used to turn on the device to which it is connected.

Note: This output will be around 0.9V lower than that connected to the PCB.

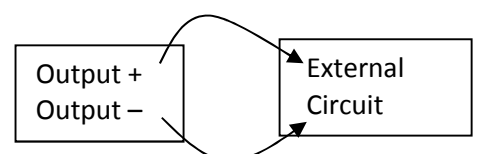

Checking Your Circuit

Check the following before you connect power to the board:

Check the bottom of the board to ensure that:

- All these leads are soldered.
- Pins next to each other are not soldered together.

Check the top of the board to ensure that:

- The body of the two transistors match the outline on the PCB.

Testing the PCB

Light activated circuit

- In daylight, turn the variable resistor R2 fully clockwise (high resistance = $47K\Omega$). At this point the output should be on (and the LED if fitted).
- Now turn the variable resistor R2 anti-clockwise until the output turns off (and the LED if fitted).
- Turn the variable resistor R2 back clockwise. Note the point at which the output (and the LED if fitted) turns back on. This is the trip point for the current light level.
- If you want the circuit to trip at a lower light level then adjust R2 forward in the clockwise direction.
- If you want the circuit to trip at a brighter light level then adjust R2 back in the anti-clockwise direction.
- Some experimentation may be required to set the correct trip point.

Dark activated circuit

- In daylight turn the variable resistor R1 fully clockwise (low resistance = $47K\Omega$). At this point the output should be off (and the LED if fitted).
- Now turn the variable resistor R1 anti-clockwise until the output turns on (and the LED if fitted).
- Turn the variable resistor R1 back clockwise. Note the point at which the output (and the LED if fitted) turns back off. This is the trip point for the current light level.
- If you want the circuit to trip at a lower light level then adjust R1 forward in the clockwise direction.
- If you want the circuit to trip at a brighter light level then adjust R1 back in the anti-clockwise direction.
- Some experimentation may be required to set the correct trip point.



How the Light Switch Works – Dark Activated

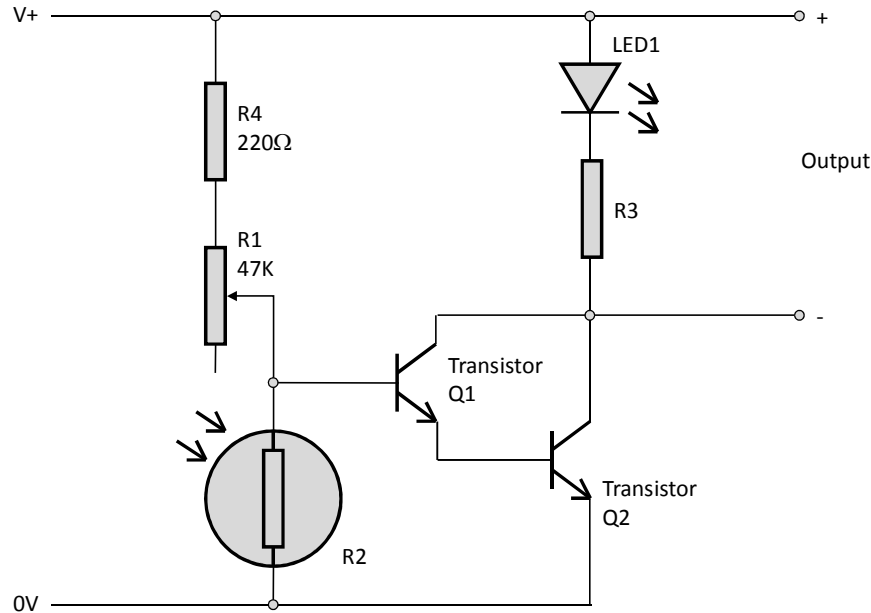

The circuit operation is very simple. When the input to the transistor Q1, which is fed from the connecting point of R1 and R2, is greater than 1.4V, the output is turned on. The voltage at the join of R1 and R2 is determined by the ratio of the two resistors. This is known as potential divider.

$$\text{Voltage at join of R1 and R2} = \text{The supply Voltage} \times (R1 / (R1 + R2))$$

Normally it requires 0.7V to turn on a transistor but this circuit uses two resistors in a Darlington Pair, meaning that it requires $2 \times 0.7V = 1.4V$ to turn on both transistors.

It is also worth noting that the output, when turned on, will be around 0.9V lower than the supply voltage V+. This is because of the voltage drop across the collector and emitter pins of the Darlington Pair of transistors. Therefore if the supply voltage is 5V, then the output voltage will be around 4.1V.

R4 is present to protect the transistor should the variable resistor be set to zero.

Adjusting the trigger level

The point at which the circuit is triggered is set by the 47KΩ variable resistor. By varying the value of this resistor, the ratio of the resistance of R1 and R2 can be varied to a point where a centre voltage (trip point) of 1.4V is achieved at the desired light level.

LED (if fitted)

If LED1 and R3 are fitted the LED will light at this point. The value of R3 should be selected for the relevant supply voltage on LED used. A standard LED would require around 10mA (0.01A) producing a normal brightness. As stated, a 5V supply would give 4.1V across LED1 and R3. The LED1 would use 1.9V, leaving around 2.2V (4.1V-1.9V) across R3.

$$\text{Using } R = V/I \quad R3 = 2.2 / 0.01 \quad R3 = 220\Omega$$



How the Light Switch Works – Light Activated

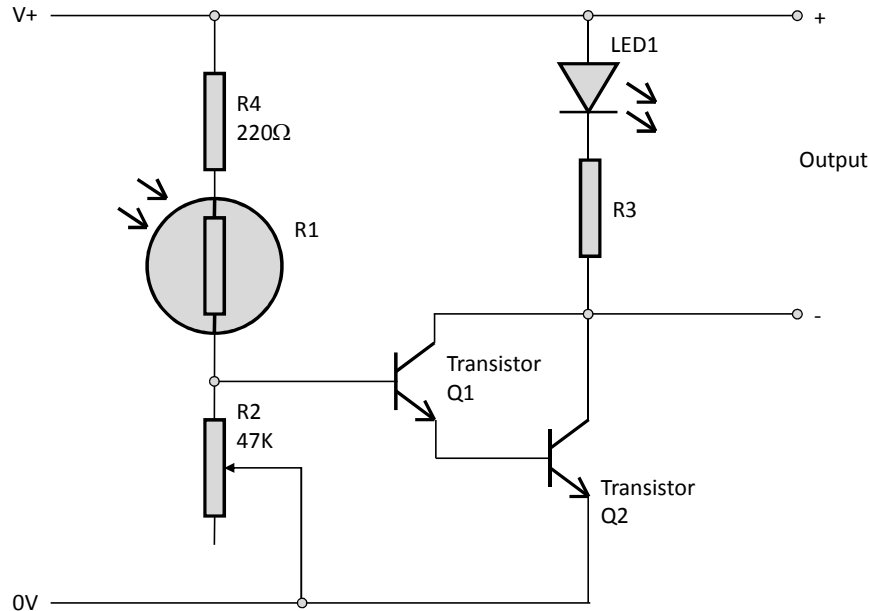

The circuit operation is very simple. When the input to the transistor Q1, which is fed from the connecting point of R1 and R2, is greater than 1.4V, the output is turned on. The voltage at the join of R1 and R2 is determined by the ratio of the two resistors. This is known as potential divider.

$$\text{Voltage at join of R1 and R2} = \text{The supply Voltage} \times (R2 / (R1 + R2))$$

Normally it requires 0.7V to turn on a transistor but this circuit uses two resistors in a Darlington Pair, meaning that it requires $2 \times 0.7V = 1.4V$ to turn on both transistors.

It is also worth noting that the output, when turned on, will be around 0.9V lower than the supply voltage V+. This is because of the voltage drop across the collector and emitter pins of the Darlington Pair of transistors. Therefore if the supply voltage is 5V then the output voltage will be around 4.1V.

Note: R4 is only present to protect the transistor in the dark activated version (when the variable resistor is set to zero).

Adjusting the trigger level

The point at which the circuit is triggered is set by the 47KΩ variable resistor. By varying the value of this resistor, the ratio of the resistance of R1 and R2 can be varied to a point where a centre voltage (trip point) of 1.4V is achieved at the desired light level.

LED (if fitted)

If LED1 and R3 are fitted, the LED will light at this point. The value of R3 should be selected for the relevant supply voltage on LED used. A standard LED would require around 10mA (0.01A) producing a normal brightness. As stated, a 5V supply would give 4.1V across LED1 and R3. The LED1 would use 1.9V, leaving around 2.2V (4.1V-1.9V) across R3.

$$\text{Using } R = V/I \quad R3 = 2.2 / 0.01 \quad R3 = 220\Omega$$



Applications

Garden lamp that switches on automatically at night

As shown to the right, by simply adding a battery holder and light bulb to a PCB built in the 'dark activated' configuration, you can create a garden light that automatically comes on in the dark.

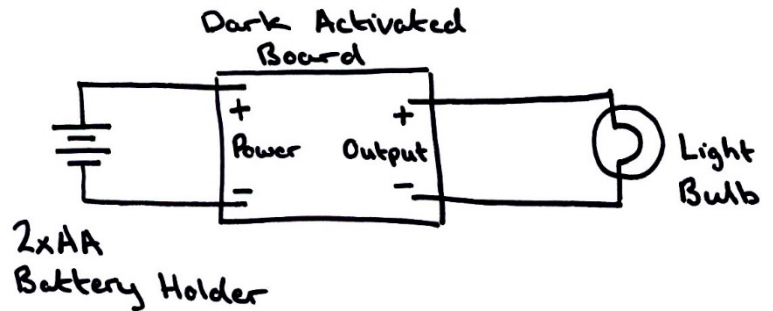

Parts list to build 100 garden lights:

Part no.	Description	Qty
2112	Light Activated Switch	100
2232-25	2 x AA Battery Cage with Leads, pack of 25	4
3517	MES Lamp Holder (Economy), pack of 50	2
3519	MES Lamp 2.5V, pack of 50	2
2201-40	Zinc Chloride AA Batteries, box of 40	5

Draw alarm, which sounds when a dark draw is opened

As shown to the right, by simply adding a battery holder, switch and buzzer to a PCB built in the 'light activated' configuration, you can create an alarm that sounds when a dark draw is opened and the PCB is exposed to light. The switch is to allow the alarm to be activated or deactivated.

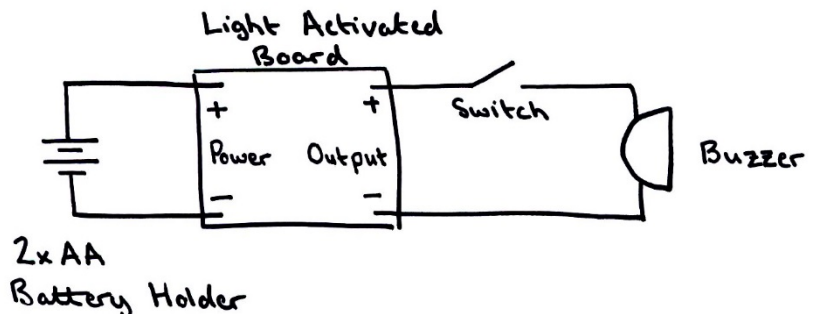

Parts list to build 100 draw alarms:

Part no.	Description	Qty
2112	Light Activated Switch	100
2232-25	2 x AA Battery Cage with Leads, pack of 25	4
3404	Miniature DPDT Slide Switch, pack of 10	10
3301	Piezo Buzzer (with Drive), pack of 10	10
2201-40	Zinc Chloride AA Batteries, box of 40	5



Light Activated Switch Essentials

Line following buggy (using 2 light activated boards)

As shown below, by using two light activated boards and two motors, it is possible to make a line following buggy. The boards just need to be mounted close to the ground with the light sensor facing down. Normally the buggy will travel in a straight line. If one of the sensors cross the dark line, it turns off the motor on that side. This will steer the buggy away from the line. Once it has been steered away from the line, the motor will turn back on. This circuit could be used with Lego motors.

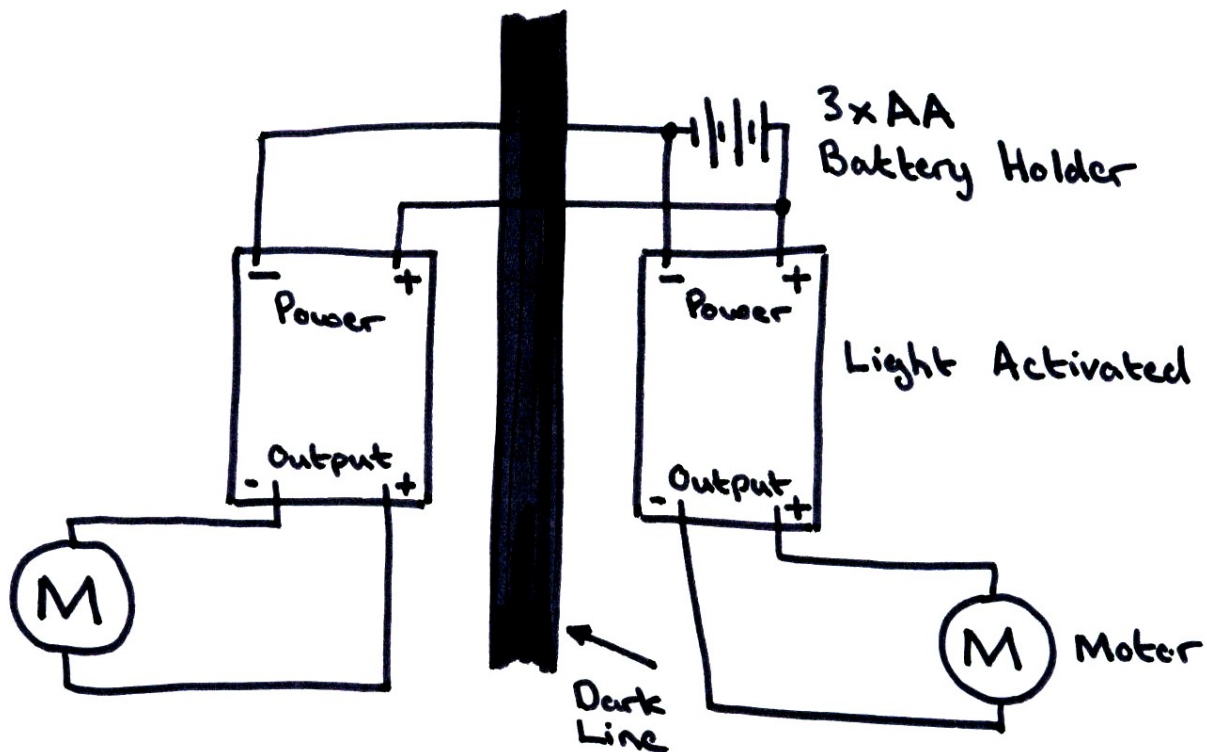

Parts list to build 100 buggies:

Part no.	Description	Qty
2112	Light Activated Switch	200
2234-25	3 x AA Battery Cage with Clip, pack of 25	4
2238-25	PP3 Battery Clip Lead, pack of 25	4
2501	Motor (Medium Torque), pack of 10	20
2505	Plastic Motor Mounting Clips, pack of 10	20
2201-40	Zinc Chloride AA Batteries, box of 40	8

Note: No gear box parts included.



Online Information

Two sets of information can be downloaded from the product page where the kit can also be reordered from. The 'Essential Information' contains all of the information that you need to get started with the kit and the 'Teaching Resources' contains more information on soldering, components used in the kit, educational schemes of work and so on and also includes the essentials. Download from:

www.kitronik.co.uk/2112



This kit is designed and manufactured in the UK by Kitronik

Telephone: +44 (0) 845 8380781

Sales email: sales@kitronik.co.uk

Tech support email: support@kitronik.co.uk

Web: www.kitronik.co.uk



www.kitronik.co.uk/twitter



www.kitronik.co.uk/facebook



www.kitronik.co.uk/youtube



www.kitronik.co.uk/google

Every effort has been made to ensure that these notes are correct, however Kitronik accept no responsibility for issues arising from errors / omissions in the notes.

© Kitronik Ltd - Any unauthorised copying / duplication of this booklet or part thereof for purposes except for use with Kitronik project kits is not allowed without Kitronik's prior consent.

